

HINO

300 Series

916



*Image may contain items not standard to the model

4 x 2 Cab Chassis

KEY FEATURES

- Emission Level: Euro 3 Standard
- Antilock Braking System (ABS)
- Full Disc Wheel Brakes
- Side Door Beams
- Telescopic and Tilt Steering Column
- AM/FM Radio with USB,AUX, Bluetooth Audio System
- SRS Airbag System

KEY SPECIFICATIONS

GVM	8,500kg
Power	150hp/110kW
Torque.	420Nm
Transmissions	6 speed Manual
Wheelbases mm	3,430-3,870-4,200
Overall Lengths mm	6,120-6,740-7,250

ENGINE

Model	HINO N04C-WH
Maximum Power	110kW (150 PS) at 2,800 r/min (ISO NET)
Maximum Torque	420 Nm (42.9 kgfm) at 1,400 r/min (ISO NET)
Maximum Engine Speed	3,100 r/min
Type	Diesel, Turbocharged and intercooled, 4-cycle, in-line 4-cylinder, overhead valve, water cooled
Combustion system	Compression Ignition, Four Stroke
Bore & stroke	104 x 118 mm
Piston displacement	4.009L
Compression Ratio	18.0 : 1
Engine Oil Capacity	9.4 L
Fuel Injection Pump	Electronic Control Common Rail Type
Air Cleaner and intake	Behind cab mounted roof-height snorkel air intake with air filter, dry paper element
Exhaust Tail	Short Tail Type

CLUTCH (MANUAL TYPE ONLY)

Type	Dry Single Plate with damper Springs, Facing outside diameter 325 mm, automatic gap adjuster
------	--

TRANSMISSION, PERFORMANCE & GEAR RATIOS

Calculations based in 7.5 ton GVM,

Production Code(s), Model & Description	XZU710L-WKFTLV3 XZU720L-WKFTLV3	XZU720L-WKFTLV3
	RE61, Manual 6-Speeds, With Overdrive	
Max speed (km/h)	132	
Gradeability tanθ (%)	45.8	
GEAR RATIOS	1	6.370
	2	3.870
	3	1.913
	4	1.461
	5	1.000
	6	0.703
	Reverse	5.926
Rear axle, Gear Ratio (:1)	5.125	
Transmission Shift Lever	Folding Type	

SERVICE BRAKE

Type	Dual-Circuit Hydraulic, Vacuum Assist
Front Wheel Brake	Disc Diameter 287 mm, pad effective area 84 cm ²
Rear Wheel Brake	Disc Diameter 287 mm, pad effective area 84 cm ²
Exhaust Brake	Equipped
ABS (Antilock Brake System)	Equipped (Power Assist Brake)

PARKING BRAKE

Type	Mechanical, Internal expanding acting on transmission output shaft, not folding lever
------	---

STEERING

Type	Telescopic and tilt steering column, recirculating ball integral power steering
------	---

POWER & TORQUE CHART (N04C-WH Performance curve)

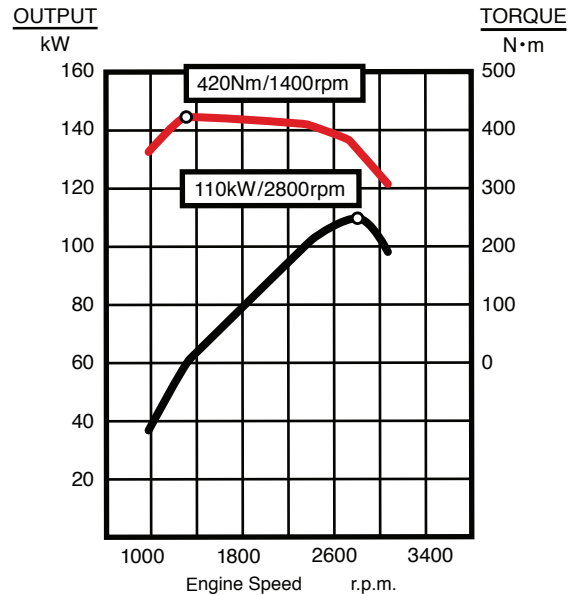

INSTRUMENTS

Speedometer	Equipped (Km/h)
Multi-Information	Equipped
Tachometer	Equipped (r/min)
Coolant Temperature Gauge	Equipped (with buzzer)
Fuel Gauge	Equipped
Brake Warning	Brake Fluid level and Vacuum Pressure warning lamp and buzzer
Seat Belt Warning	Equipped
Cab Tilt Warning Lamp	Equipped (with Indicator Light and Buzzer)
Auto transmission Fluid Temperature Warning	Equipped (with Indicator Light, Auto Model only)

PROPELLER SHAFT

Tube outside Diameter x Thickness	82.6 x 2.3 mm
-----------------------------------	---------------

AXLE, SUSPENSION

FRONT	Front Axle Type	Reverses Elliot, "I" Section Beam
	Suspension	Semi-Elliptic tapered leaf springs with double acting shock absorbers
REAR	Rear Axle Type	Full-Floating, Single Reduction, Single Speed by hypoid Gearing
	Suspension	Semi-elliptic main and auxiliary tapered leaf springs with double acting shock absorbers

FUEL TANK

Production Code	XZU710L-WKFTLV3	XZU720L-WKFTLV3	XZU720L-WKFTLV3
Tank Capacity	100L	100L	150L
Fuel Filler	Small Diameter Neck		
Fuel Filter	Primary (with Water Separator) and Secondary Filter		

WHEELS & TYRES

Tyre size	7.50R16-14
Spare tyre carrier	Equipped (Rear End)

Note: All Specifications of the products are with Normal Manufacturing allowances and tolerances. Hino Motos, Ltd. Reserves the right to alter specifications at any time without prior notice. Figures of axle capacity can be changed by the operating conditions and specifications of equipments concerned.

CHASSIS FRAME

Type	Ladder-Shaped Channel Section Side Rails
Front Bumper	Dark Grey Type (Resin)
Rear Bumper	Equipped
Front Underrun Protector	Equipped
Max. Section (depth x flange x thickness)	192.8 x 65 x 5.9 mm
Rear Frame width (at rear)	750mm
Tensile Strength	540 N/mm ² (55 kgf/mm ²)
Tow Hook	Equipped (Front)

ELECTRICAL EQUIPMENT

System Voltage	24 volt
Batteries	60 Ah (216 kC) at 20-hourrate 55D23L (2)
Alternator	24 V, 60 A
Starter	24 V, 4.5 kW
Headlight	Halogen Type
Diagnoses Connector	Equipped
Horn	Electric Type, Single
Back-up Buzzer	Equipped
Headlight Leveling	Manual Type
Position Light	Equipped (with Parking Light Mode)
Turn Signal Light (front)	Equipped
Stop, Turn, Tail light	Equipped (EC type)
Rear Fog Light	Equipped

CHASSIS DIMENSIONS (mm) :

All dimensions are to standard specifications and unladen chassis

Model Description	HINO 3916		
Product Code	XZU710L-WKFTLV3	XZU720L-WKFTLV3	XZU720L-WKFTLV3
Product Code	General Use		
Wheelbase (WB)	3430	3870	4200
Overall length (OL)	6120	6740	7250
Overall width (OW)	2055	2055	2055
Overall height (OH)	2260	2260	2260
Cab to Axle centre (CA)	2860	3300	3630
Front Overhang (FOH)	1115	1115	1115
Rear Overhang (at Frame end)	1575	1755	1935
Front Chassis Height (HF)	750	750	750
Rear Chassis height (HR)	810	810	810
Road Clearance (at diff. case) (RC)	200	200	200
Front Tread (FT)	1,655	1,655	1,655
Rear Tread (RT)	1,590	1,590	1,590
Turning Radius on tire	6200	6900	7400
Turning Radius wall to wall	6900	7600	8100

CAB

Type	Forward control, all steel welded construction, high roof, mechanical tilt with torsion assist
Windshield wiper	2-Speed with Wash and Intermittent Feature
Radiator Grille	Cab Colored Type
Outside rearview mirrors	EC type, Long stay with Arabic Caution
Front windshield	Heat absorbing laminated glass
Seating Capacity	Three (3)
Front Seat	4-way adjustable driver seat, fixed back passenger seat integrated type
Instrument Panel Center Cluster	Dark Grey Color
Seat Cover	Fabric Type
Seat belts	3-point ELR (Emergency Locking Retractor) belt on driver and outer passenger seat, 2-point NR (Non Retractor) belt on Center Seat
Grab Handle (interior)	Equipped (driver 1 + passenger 1)
Sunvisor	Equipped (both Sides)
Door Pocket	Equipped (both Sides)
Inside Mirror	Equipped (EC type)
Cab Trim (Quarter Panel)	Semi Trim
Car Audio	AM/FM Radio with USB, AUX, Bluetooth (2 Speakers)
Air Conditioner	Equipped (with clean air Filter)
Heater and Defroster	Equipped (with Warm up Switch)
Room Light	Equipped
Door Courtesy Switch	Driver Side
Seat Back Pocket	Equipped (Driver Side)
Cigar Lighter	Equipped
Cup holders	Equipped
Tool Set	Equipped
Hydraulic Jack	Equipped
Floor Mat	Vinyl Type
SRS Airbag System	Equipped (Driver and Passenger)
Overhead Console	Equipped (both Sides)
Power Window	Equipped
Power Door Lock	Equipped

CHASSIS MASS (KG):

Chassis mass quoted is to standard specifications with spare tire and standard tool set

Production code Fuel: Full	XZU710L-WKFTLV3	XZU720L-WKFTLV3	XZU720L-WKFTLV3(Auto)
Total	2565	2580	2600
Front	1600	1620	1630
Rear	965	960	970

RATINGS & AXCEL LOAD LIMIT (KG)

	GVM	Front Axle	Rear Axle
Ratings	7500	2880	5480
Axle Load Limit	7.50R16-14	2880	5480

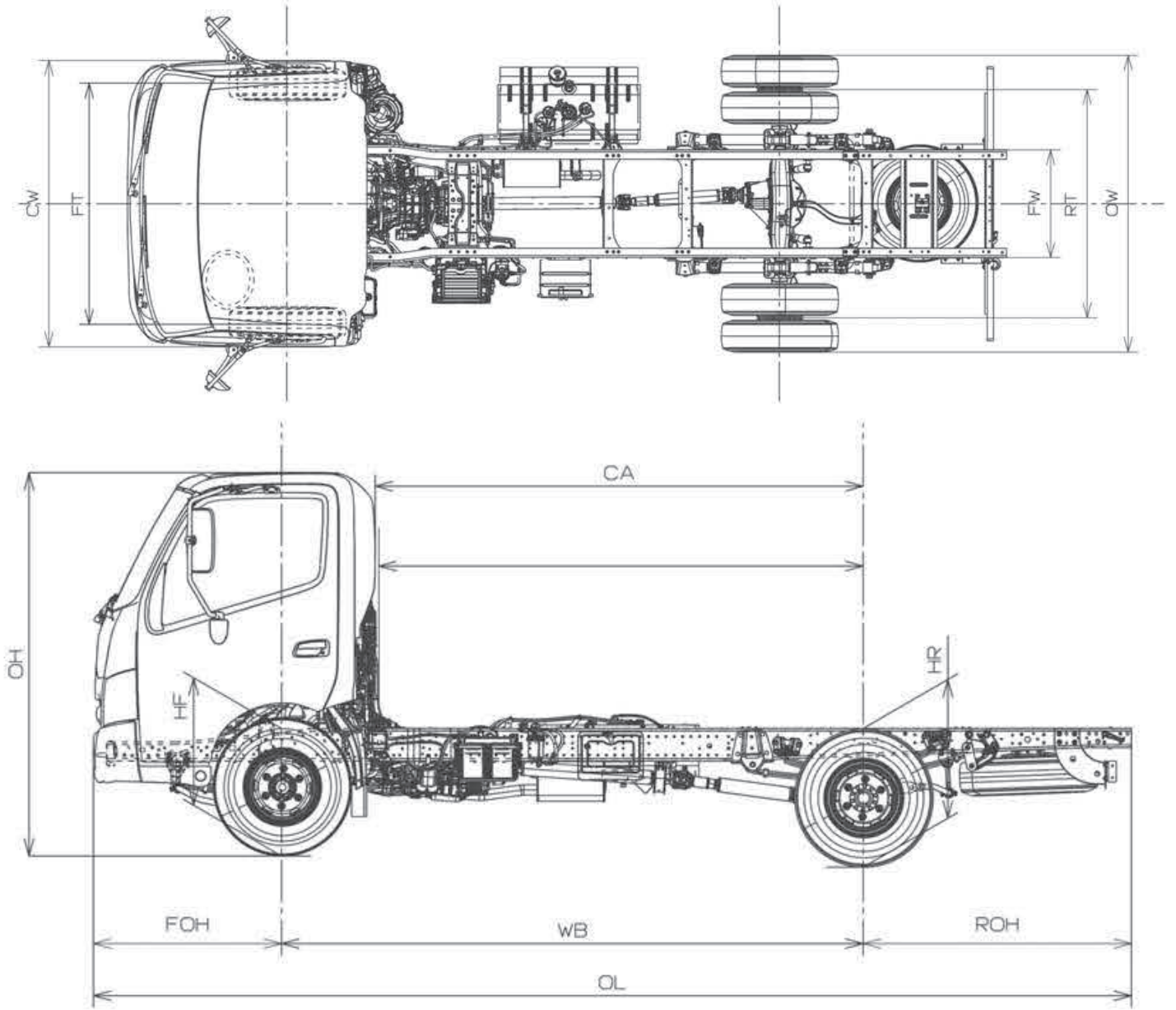

Strong Product Support

دعم قوي لمنتجاتنا

الضمان
٣ سنوات أو ١٠٠,٠٠٠ كم



WARRANTY
3 YEARS or 100,000 KMs

جودة خدمة هينو



HINO
QUALITY SERVICE

قطع غيار هينو الاصلية



HINO GENUINE PARTS

فئات مختلفة من
عقود الصيانة



VARIOUS CATEGORIES OF
SERVICE CONTRACTS

الدعم الكلي



TOTAL
SUPPORT

TSUSHO JAMJOOM

92 000 95 44



/HINOTrucksKSA

/HinoTrucksSaudiArabia

الدمام
٩٠٥٨ طريق الملك فهد
حي القشلة الظهران
٣٤٢٣٢-٣٦٩١

الرياض
٤٧٨٢ طريق خريص
حي النهضة الرياض
١٣٢٢١-٥١٠٩

المدينة المنورة
٣٢٠٥ طريق المطار حي
الدويخلة المدينة المنورة
٤٢٣٦٨-٨٦٠٨

خميس مشيط
٥٢٩٨ طريق الملك فهد
حي أم سرور خميس مشيط
٦٢٤٦١-٧٥٦٧

جدة
٧٩٤٢ شارع مدائن الفهد
حي النزلة الشرقية
٢٢٣٣٥-٣٦٩١

